

Electric Strike ES 700

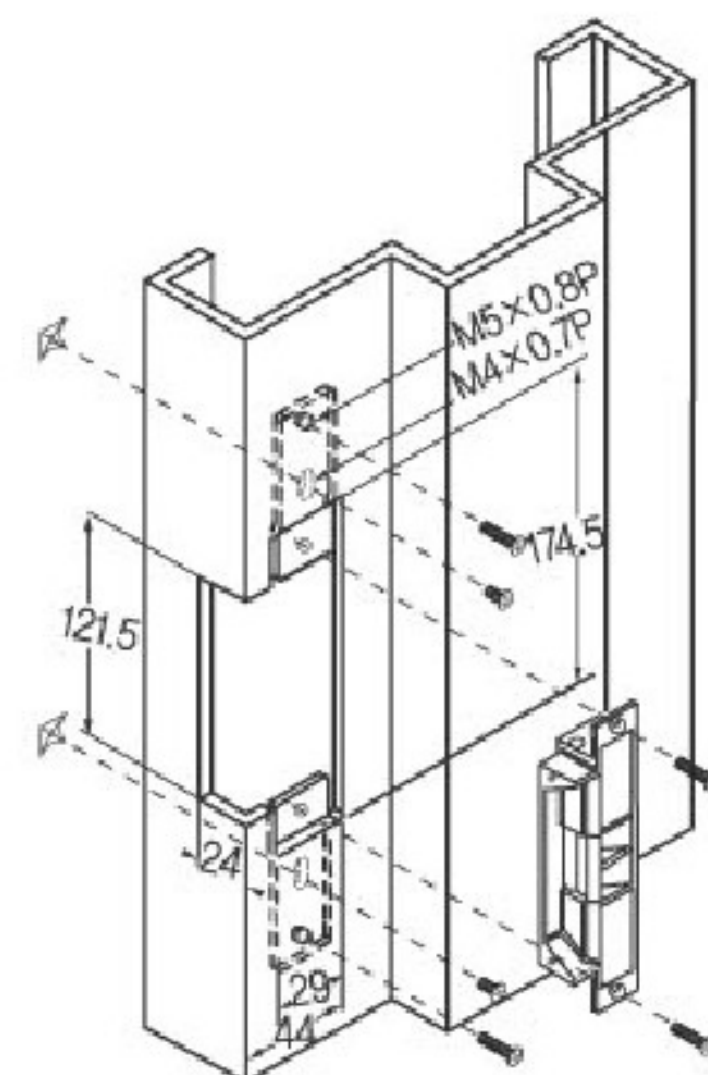

Dimensions

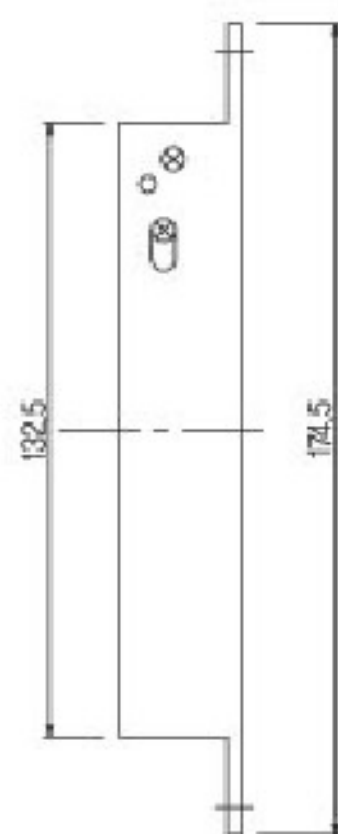
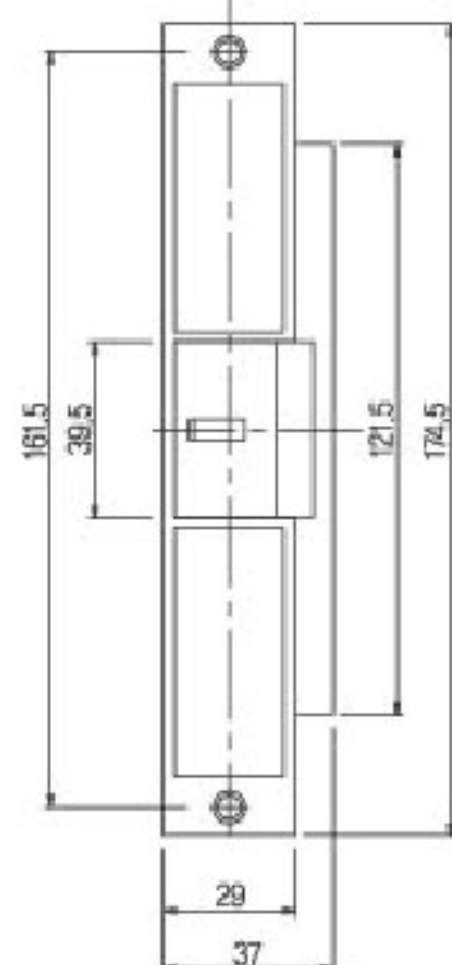
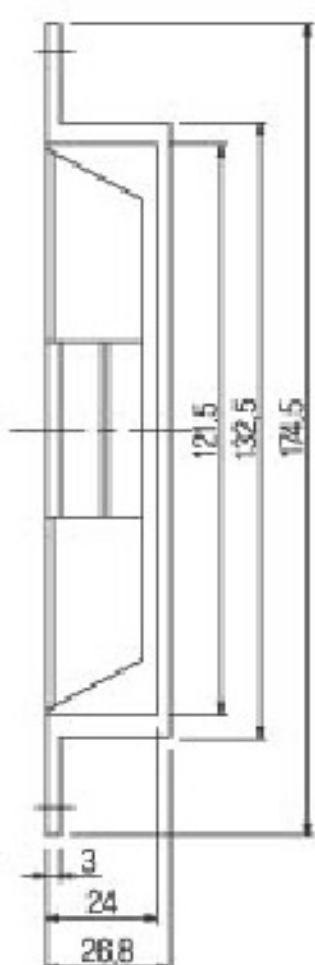
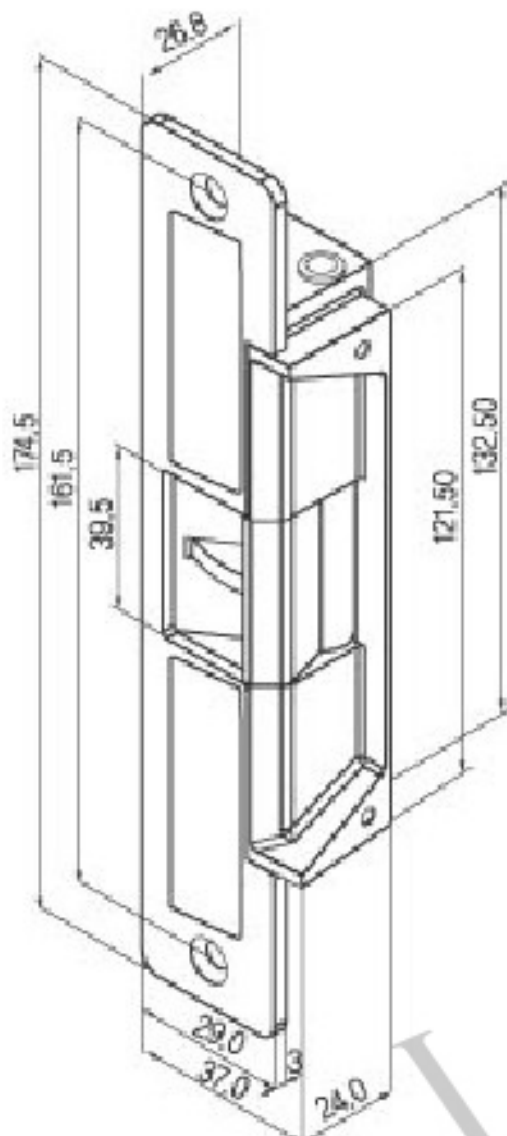

Unit: mm

Statement

The ES700 series electric strikes are designed for use with lockset spring latch or cylindrical, Max. latch throw 15mm keeper depth for inswing doors.

Features

- Version Changeable (Fail-Secure / Fail-Safe)
- Long Life Solenoid
- Maximum Latch Throw : 15mm
- Lock & Unlock / Door Status Output
- 12~24VDC/AC Operating Voltage
- For Wood Frame / Metal Frame Doors
- Remark : **CE** Approved

Specifications

- Operating Voltage : 12~24VDC/AC
- Current Draw : 210mA/12VDC, 140mA/24VDC (at temperature 20°C)
- Reed Switch Rating : 1A/125VAC
- Operating Temperature : -10~ + 45°C
- Humidity : 0~95% non-condensing
- Tested to 1,000,000 cycles (solenoid)
- 1000kg jaw strength pull testing
- Material : zinc alloy main stand, stainless steel faceplate

Version Changeable on Site

The ES700 Series Electric Strikes can easily be changed to Fail-Safe and Fail-Secure Mode.

